

Installation Instructions



AIR / FUEL RATIO REGULATOR (AFR)

TYPE D
PART # 4604-RT001

NOTICE

This manual assumes that you have and know how to use the tools and equipment necessary to safely perform service operations on your vehicle. This manual assumes that you are familiar with typical automotive systems and basic service and repair procedures. Do not attempt to carry out the operations shown in this manual unless these assumptions are correct. Always have access to a factory repair manual. To avoid injury to yourself and to others, follow the safety precautions contained in the factory repair manual.

BULLET CONNECTOR INSTALLATION

1. Remove a small section of insulation at the end of the wire to expose the wire strands.
2. Determine which connector (male/female) is needed.
3. Install the appropriate clear cover over the wire.
4. Crimp the center section of the connector onto the exposed wire strands.
5. Crimp the rear section of the connector onto the insulated portion of the wire.
6. Pull on the wire and the connector to confirm a good connection.

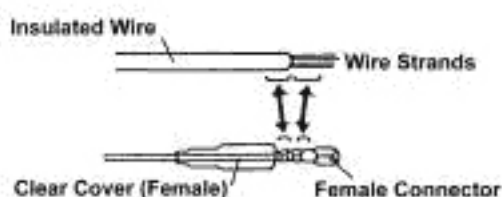
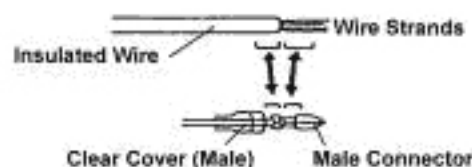

SPLICE CONNECTOR INSTALLATION

1. Place the wire to be spliced into side A (the side without the stopper) and the wire from the AFR to side A (the side with the stopper). Make sure the wire touches the stopper.
2. Fold side B over side A using pliers, making sure the snap is secured.
3. Fold side C over and make sure it snaps completely closed.
4. NOTE: Do not strip wire ends. Gently pull on the wire to insure a proper splice.



Installation Instructions



AIR / FUEL RATIO REGULATOR (AFR)

TYPE D

PART # 4604-RT001

AFR INSTALLATION

1. Disconnect the negative battery cable from the battery.
2. Confirm that the AFR you purchased is the correct application for your vehicle.
The D type AFR is used for a pressure sensor (D-Jetro) equipped vehicle and the L type AFR is used for vehicles equipped with hot wire type air flow meter systems.
3. To start, set the AFR switch to channel 6. This sets the AFR in the default position.
4. Locate the factory ECU using the factory shop manual or the AFR wiring chart portion of this manual. If the vehicle is equipped with an HKS FCD, install the AFR between the FCD and the factory ECU.
5. Examine the AFR wiring chart diagram using the factory repair manual as a reference and confirm the locations of:
 - (B) Power source wire (12 volt ignition on)
 - (E) Ground wire
 - (P) Pressure sensor (MAP)
6. Connect the AFR as shown in the diagram.
 - Connect the red wire (B) to a power source.
 - Connect the black wire (E) to a ground source.
 - Cut pressure sensor wire.
 - Connect the yellow AFR wire (P) to the wire going to the factory ECU. Connect the white AFR wire (P) to the factory ECU wire going away from the ECU.
 - Mount the AFR using double sided tape. If the adjustment switch cannot be reached easily, do not mount the AFR unit until adjustments are finished.
7. Re-examine all wire connections for proper installation.
8. Reconnect the negative battery cable to the battery.

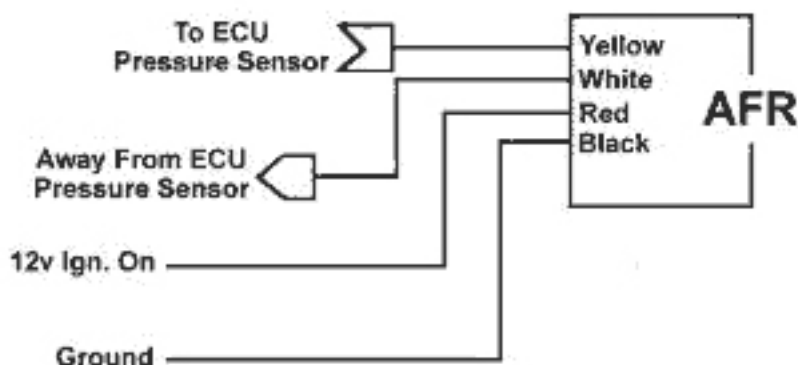

SYSTEMS CHECK

1. Inspect installation once again. Incorrect or loose wiring may cause damage not only to the AFR, but also to the vehicle itself.
2. When the following symptoms occur, check wiring for correct installation.
 - Check engine light illuminates while the engine is idling.
 - Engine does not rev up smoothly.
3. Turn off the engine before changing the dial position of the AFR.
4. Confirm that the dial is in a selected channel. If the dial is in between two channels, the AFR will not function properly.

Installation Instructions



AIR / FUEL RATIO REGULATOR (AFR)

TYPE D
PART # 4604-RT001

OPERATION OF THE AFR

1. Start the engine after the installation of the AFR to confirm that the engine runs and revs up smoothly.
2. Turn the engine off, and then turn the adjustment dial to adjust the air/fuel ratio.
 - Channel #6 should not alter the air/fuel ratio (default). This is the stock setting.
 - Each channel will change the air/fuel ratios approximately 0.2 percent depending on which channel is selected.
 - The air/fuel ratio will become leaner when the dial is turned to the negative side (channels 5 to 1), and will be richened when the dial is turned to the positive side (channels 7 to 12).
 - When changing the OEM air filter to a Super Mega Flow and / or exhaust, the air/fuel ratio will become leaner, therefore it is recommended to turn the AFR to the positive direction (channels 8 to 10).
 - After the adjustments are done, cover the adjustment dial on the AFR with an enclosed green "close" sticker.



AFR WIRING DIAGRAMS

The following diagrams may differ slightly depending on vehicle year or model (California or Federal). Confirm that the diagram shown corresponds to your vehicle by referencing the factory repair manual.

*ALL DIAGRAMS ARE SHOWN FROM THE WIRE SIDE OF THE HARNESS

1988-91 Honda Civic & 1986-93 Acura Integra

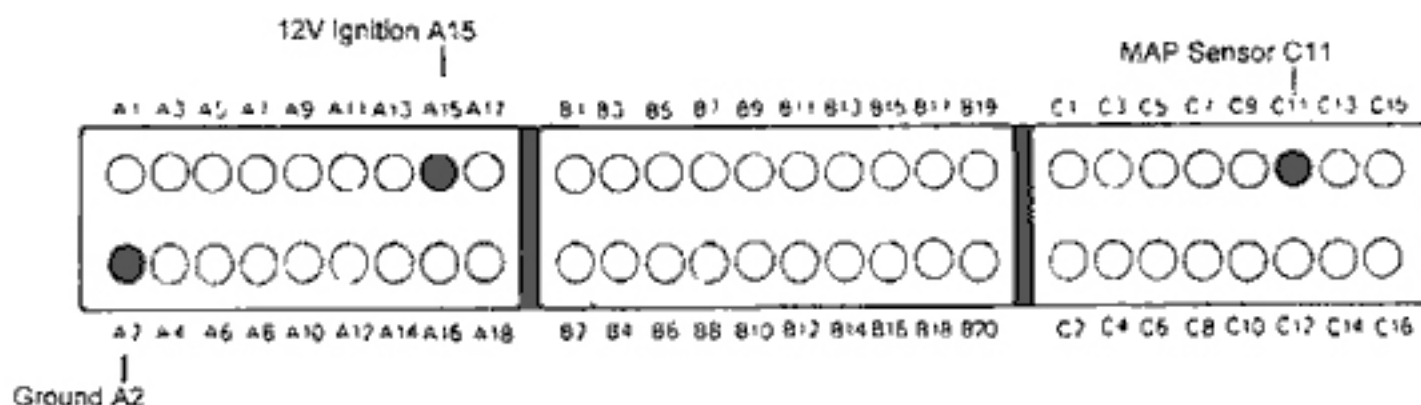

Installation Instructions



AIR / FUEL RATIO REGULATOR (AFR)

TYPE D
PART # 4604-RT001

1992-95 Honda Civic / 1993-96 Del Sol / 1990-93 Accord / 1992-96 Prelude
1994-98 Acura Integra GS, LS & RS

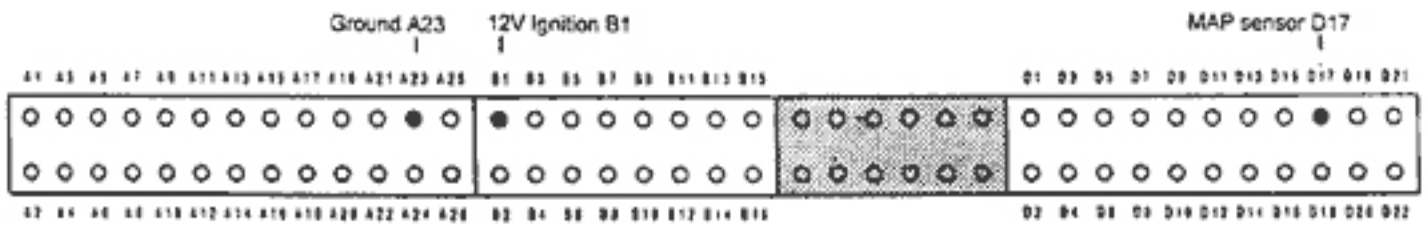

1994-97 Honda Accord / 1996-98 Civic

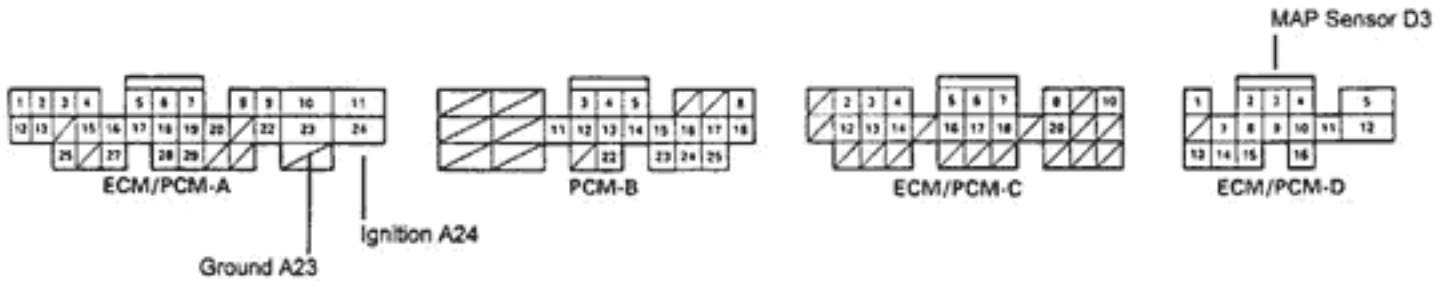

1997-98 Acura Integra Type R / 1995-98 Integra GSR

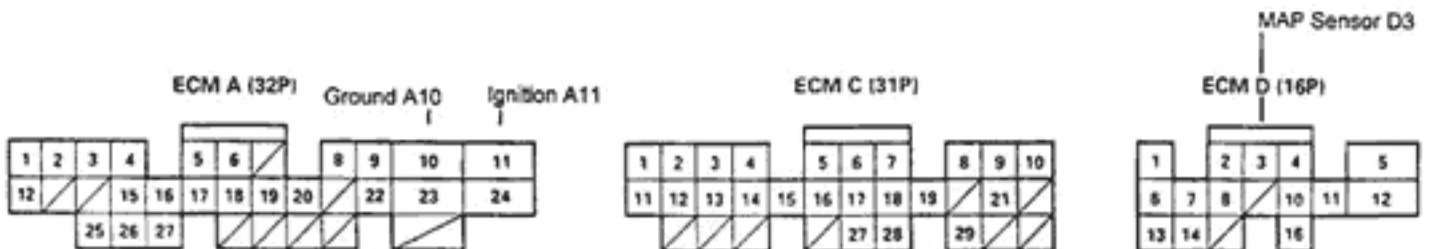

Installation Instructions



AIR / FUEL RATIO REGULATOR (AFR)

TYPE D
PART # 4604-RT001

PARTS LIST

QUANTITY	DESCRIPTION	COMMENTS
1	AFR Unit	D type
2	Splice Connectors	red
1	Male Connector	
1	Female Connector	
1	Plastic Cover	male
1	Plastic Cover	female
2	Tie Wrap	